

Pneumatic Pinch Valves type VA - stainless steel design

 The ideal valve solution for abrasive, corrosive and fibrous products like granules, powders, suspensions, sludge/slurries, dust and so on.

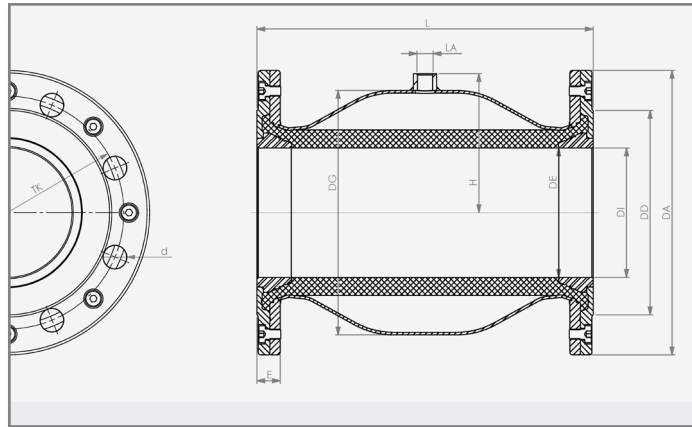

Materials:

Valve body:

Stainless steel AISI 316L (1.4404)

Flanges:

Stainless steel AISI 316L (1.4404)

Sleeves:

Natural rubber anti-abrasive, natural rubber food, natural rubber high temperature, nitrile, nitrile food, EPDM, EPDM food, viton, silicone, neoprene, hypalon, butyl.

Accessories:

Solenoid valves, pressure switch, pressure relief valves, safety arrangement, vacuum unit etc.

See accessories data sheet Z01.

Industrial areas:

Wine Industry / Pharmaceutical Industry / Food Industry / Beverage Industry / Chemical Industry / Offshore Industry and many more

- Complete AISI 316L (1.4404)
- Free passage
- Optimum tightness
- Low resistance
- No plugging
- Low weight
- Easy maintenance

DN (mm)	Type	DI (mm)	DE (mm)	DG (mm)	DA (mm)	DD (mm)	d (mm)	screws	TK (mm)	L (mm)	LA	H (mm)	E (mm)	P max (bar)	weight (kg)	Volume (l)* (ca / approx)
40	VA	40	40	84	150	88	18	4	110	156	G 3/8"	53	18	6	4,7	0,27
50	VA	50	50	100	165	102	18	4	125	165	G 3/8"	63	18	6	5,7	0,44
65	VA	65	65	132	185	122	18	4	145	180	G 3/8"	76	28	6	7,1	0,76
80	VA	80	80	160	200	138	18	8	160	212	G 3/8"	90	18	6	8,2	1,66
100	VA	100	100	190	220	158	18	8	180	260	G 3/8"	110	18	6	11,0	2,88
125	VA	125	120	240	250	184	18	8	210	340	G 3/8"	134	23	6	16,6	6,00
150	VA	150	145	287	285	212	22	8	240	406	G 1/2"	160	23	4	22,0	15,00

* Volume = Control volume with closed sleeve
Diameter DN200 and DN250 available on request.

Technical changes kept in reserve.

AKO UK Ltd

13 Alvis Way, Royal Oak Trading Estate, Daventry, Northampton Nn11 8PG8

Tel: 0 13 27 31 27 47 ▪ Fax: 0 13 27 31 25 65 ▪ E-mail: sales@ako-valves.com ▪ Web: www.ako-valves.com